

HBG-24

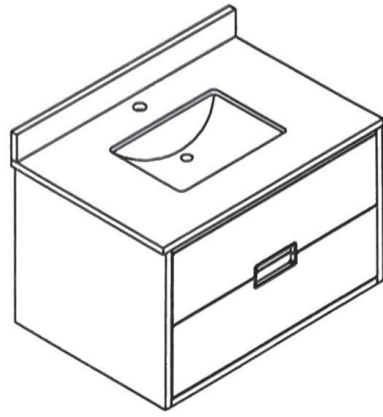

HBG-30

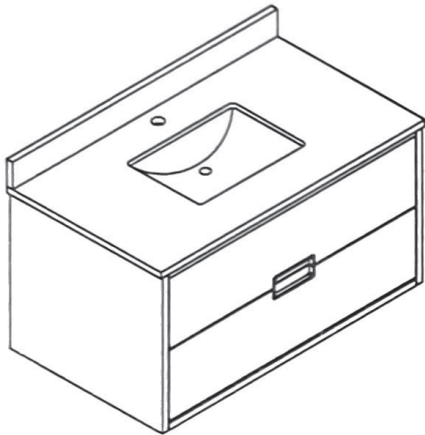

HBG-36

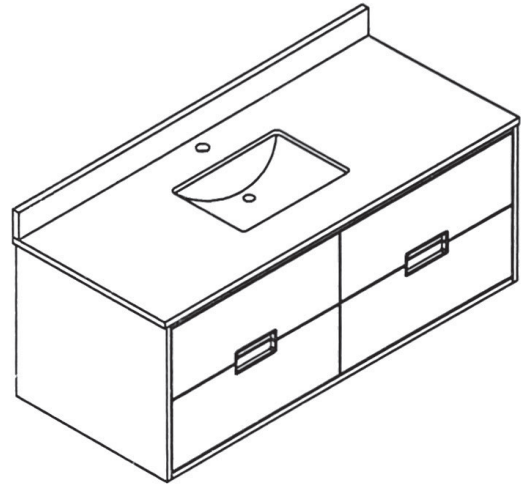

HBG-48

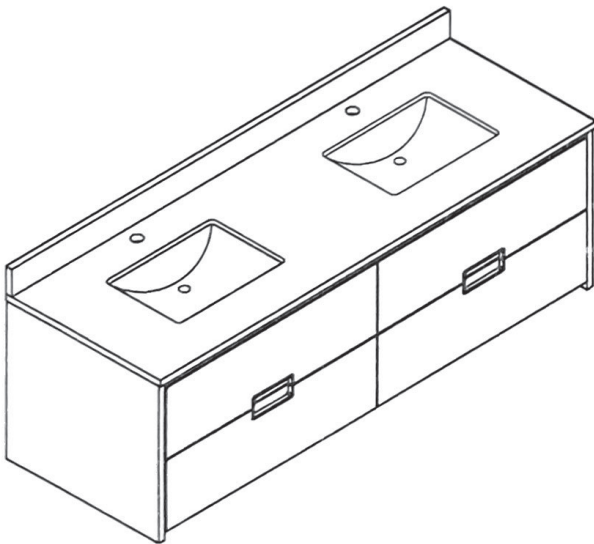

HBG-60

#1

INSTALLATION

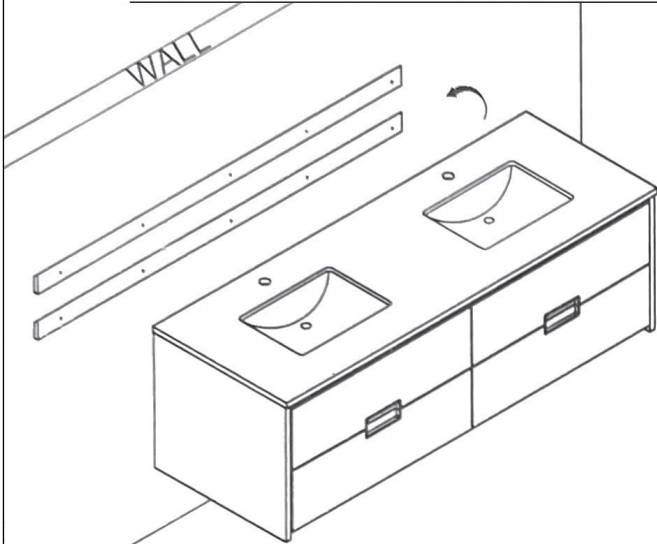
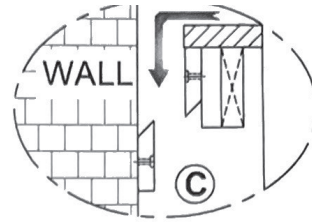
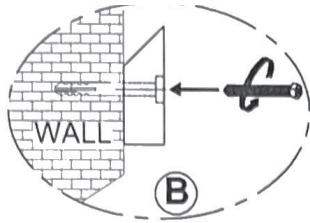
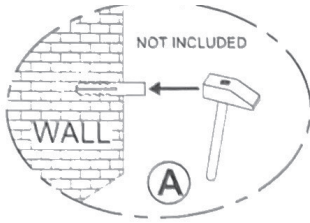

#2

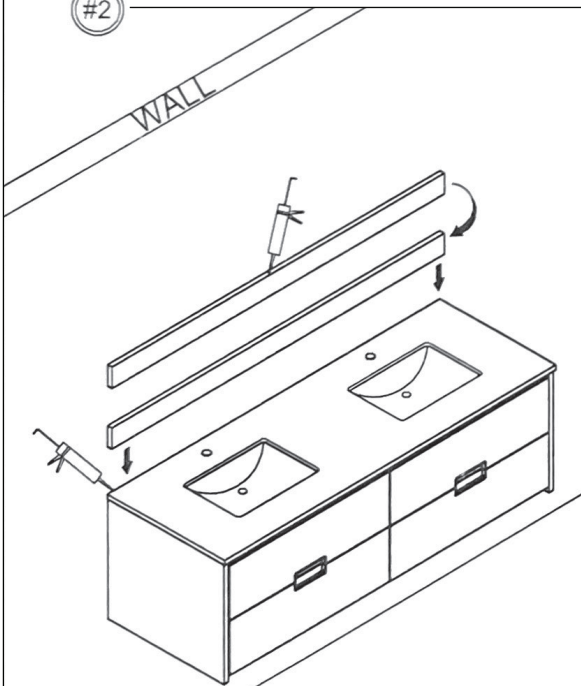

A B

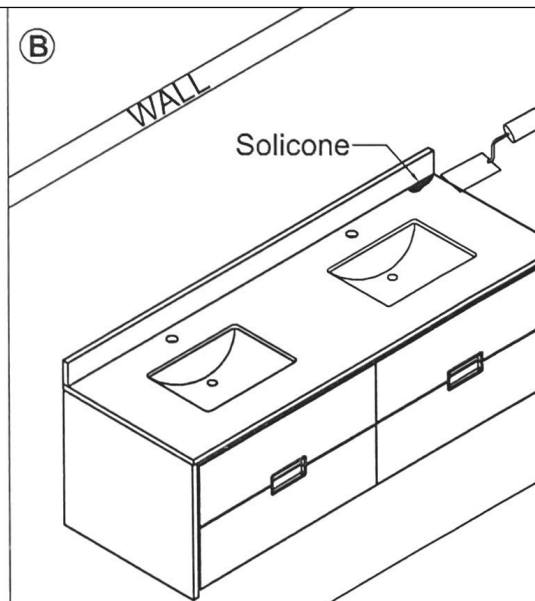

TOOLS REQUIRED (not supplied)



INSTALLATION

#3

24h!

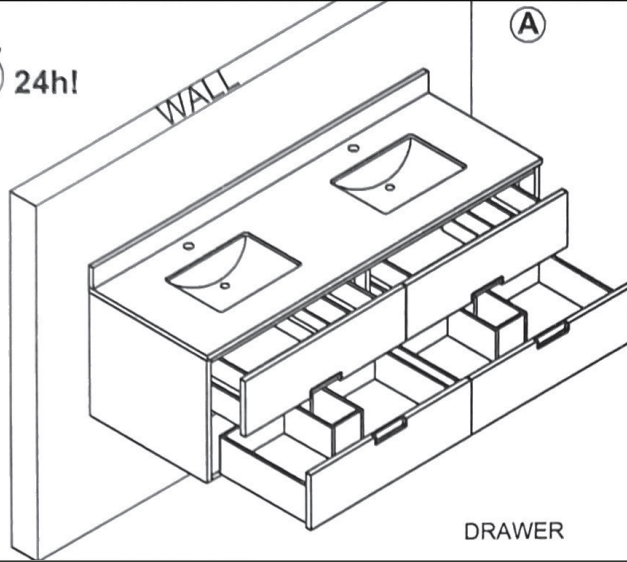

#4

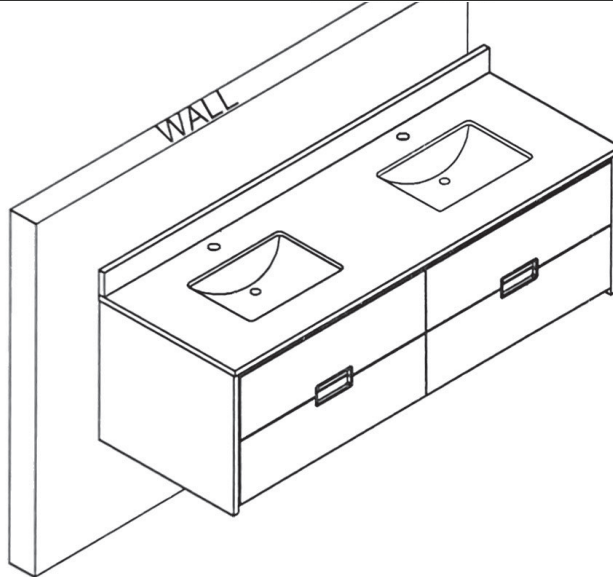

REMOVE

INSTALL

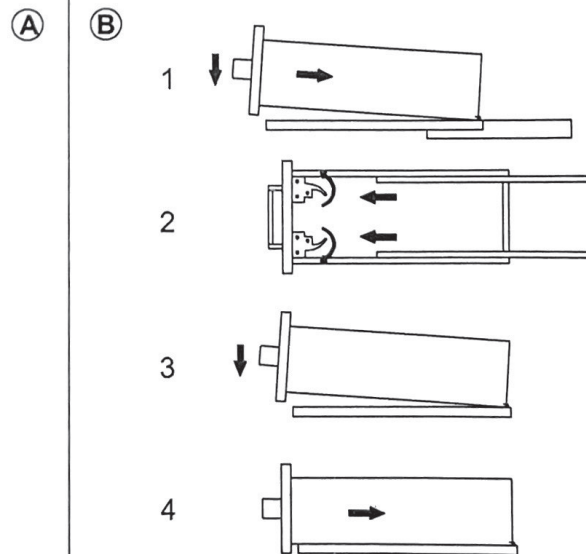
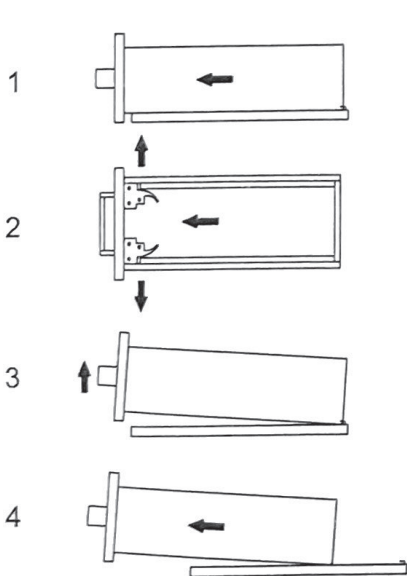

CARE INSTRUCTIONS

Handling a Countertop

- When moving a stone countertop, please consider the following:
- The stone should be right side up in the horizontal position.
- Ensure multiple individuals possess the necessary physical capabilities required to lift heavy, oversized objects.
- Perform the lifting and lowering actions slowly, engaging your knees and using leg strength.

Quartz

Quartz exhibits superior properties through its durability, strength, and resistance to scratches and substances. Due to its non-porous nature, the preservative of the stone's health requires no sealant or finishes.

Maintenance and Care

Your countertops will require some care to maintain the desired luxurious look over time. Marble stones are porous by nature, making them susceptible to staining. While we take extra care during our finishing and sealing processes, please be sure to avoid the use of any chemical cleaners, acidic solutions, abrasive textures, or any products that contain lemon, vinegar, or wine.

- When a spill occurs be sure to blot the affected area using a clean cloth dampened with warm water. If necessary, use a mild amount of dishwashing detergent or a stone soap. Thoroughly rinse the soap, then dry with another cloth.
- Cleaning daily with warm water will promote the health and appearance of the stone.
- Use a soft cloth to wipe away any dust buildup.
- Use a soft cloth to dry any water buildup.
- Use mats underneath and hard/sharp objects to avoid chipping and scratches.
- Avoid placing hot objects directly on the stone.
- Avoid the use of abrasive textures, chemical cleaners, acidic solutions, or any products containing lemon, vinegar, or wine.
- Reapplication of finishes and sealants of marble once a year will ensure longevity.